

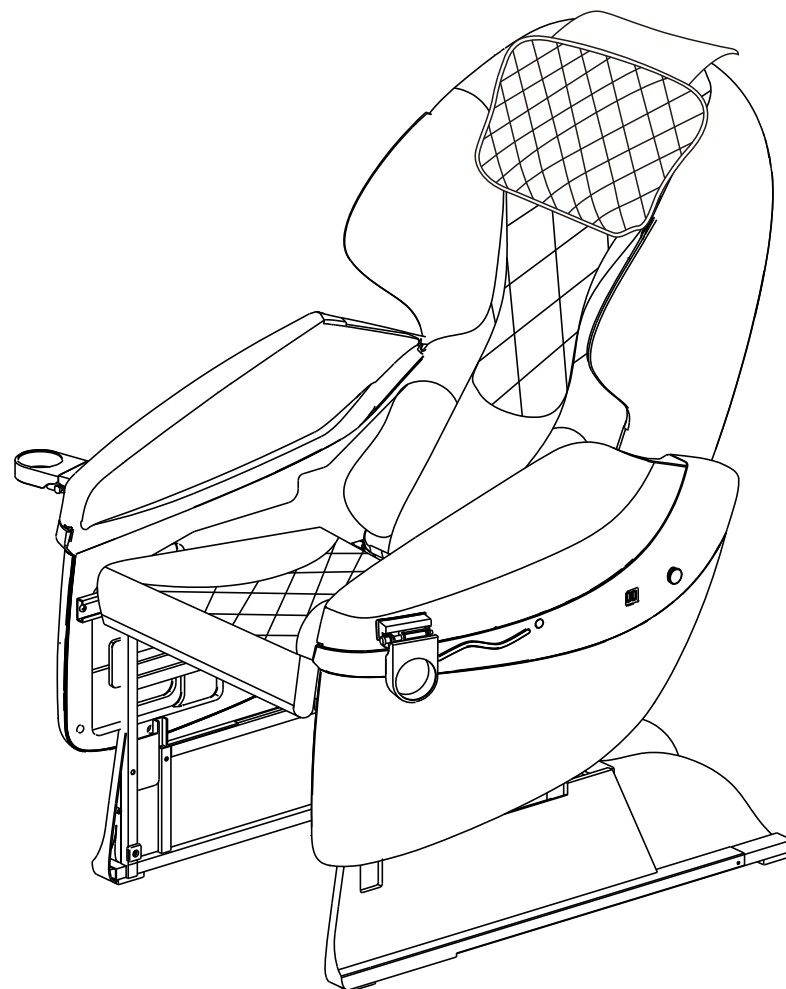

MASSAGE CHAIR

G501 SPA Operation Instructions

SAVE THESE INSTRUCTIONS



Thanks for purchasing this product. Please read this manual instruction carefully in order to know how to use this product correctly before operation. Please pay more attention to some important safety warning and keep this manual book properly for future use.

Note: Our Company reserves the right to revise the design and description of this product without any further notice. Please refer to the actual color of this product.

CONTENTS

Important Safety Warning	02
Name and function of components	04
Function	05
Method of usage	06
Product specification	13

IMPORTANT SAFETY WARNING

1. IMPORTANT SAFETY WARNING.



- Don't allow children to touch moveable part of this product.
- Please use well-grounding power supply suited to this product.
- Please pull out the plug after use or before cleaning to avoid injury or Damage to the product.
- Please operate this product according to this manual instruction.
- Don't use accessories which are not recommended.
- Don't use this product outdoors.
- Please read this manual instruction carefully before operation.
- Any other usage that is not listed in this manual instruction is forbidden.
- 20 minutes of usage each time is recommended.
- Please don't use it if the leather is broken or damaged.
- Please don't use it if the cover or leather is damaged.
- Please don't use it if the radiator hole is covered or blocked.
- Please don't drop anything into this product.
- Please don't fall asleep while using this product.
- Please don't use it if drunk or feel unwell.
- Please don't use it within one hour after having meal.
- Please don't make the massage function too strong for avoiding Injury.

2. Environment for usage.

- Please don't use it under high temperature and moist environment such as bathroom.
- Please don't use it immediately while the environmental temperature changes sharply.
- Please don't use it under heavy-dusty or caustic environment.
- Please don't use it where there is not enough space or not good ventilation.

3. People who are not suitable to use this product.

- People who are suffering from osteoporosis are not suitable to use this product.
- People who are suffering from heart disease or carrying electronic medical equipment such as heart pacemaker are not suitable to use this product.
- People who are suffering from fever are not suitable to use this product.
- Pregnant women or women that are in menses period are not suitable to use this product.
- People who got injured or skin disease are not suitable to use this product.
- Children under 14-year old or people mentally unbalanced without being Supervised are not allowed to use this machine.
- People who are told by doctor to have rest or people who feel unwell are not suitable to use this product.
- People whose bodies are wet are forbidden to use this product.

4. Safety.

- Check the voltage if it is suitable to the specification of this product.
- Don't use wet hand to pull the plug.
- Don't make water go inside this product to avoid electric shock or cause damage to this product.
- Don't damage the wires or change the circuit of this product.
- Don't use wet cloth to clean the electric parts such as switch and plug.

Safety and maintenance

- Be away from this product under power cut state to avoid injury if the power comeback suddenly.
- Stop using this product while it works abnormal, and please consult local agent immediately.
- Stop using this product if you feel unwell, and please consult health care doctor.
- This appliance is not intended for use by persons (including children) with reduced physical, sensory or mental capabilities, or lack of experience and knowledge, unless they have been given supervision or instruction concerning use of the appliance by a person responsible for their safety.
- Children should be supervised to ensure that they do not play with the Appliance.
- If the supply cord is damaged, it must be replaced by the manufacturer, its Service agent or similarly qualified persons in order to avoid a hazard.

5. Maintenance.

- This product should be maintained by certain appointed agents, users are prohibited to disassemble or maintain by themselves.
- Please don't forget to cut the power after usage.
- Don't use this product if the socket looses.
- If this product will be left unused for long, please curl up the wires and reserve this product in dry and dustless environment.
- Don't reserve this product under high temperature or near fire and avoid longtime direct sunshine.
- If the detachable cord / supply cord is damaged, it must be replaced by the manufacturer, its service agent or similarly qualified persons in order to avoid a Hazard.
- Please clean this product by dry cloth. Don't use thinner, benzene or alcohol.
- The mechanical components of this product are specially designed and made, it is not necessary to be specially maintained.
- Don't use edged res to thrust this product.
- Don't roll or pull this product above uneven ground, it should be lifted before moving.
- Please use it intermittently; don't make this product work continuously for long.

6. Solution of ordinary malfunctions.

- It is nature movement voice if the motor sounds while in usage.
- If the controller can't work normally, please check the plug and socket if they are connected strongly and make sure the switch is turned on.
- If the rated working time is over, the product will automatically activate the power-off button; If this product works continuously for long, the temperature protector will make the product automatically power-off, it should be used again after half an hour's rest.

Name and function of components

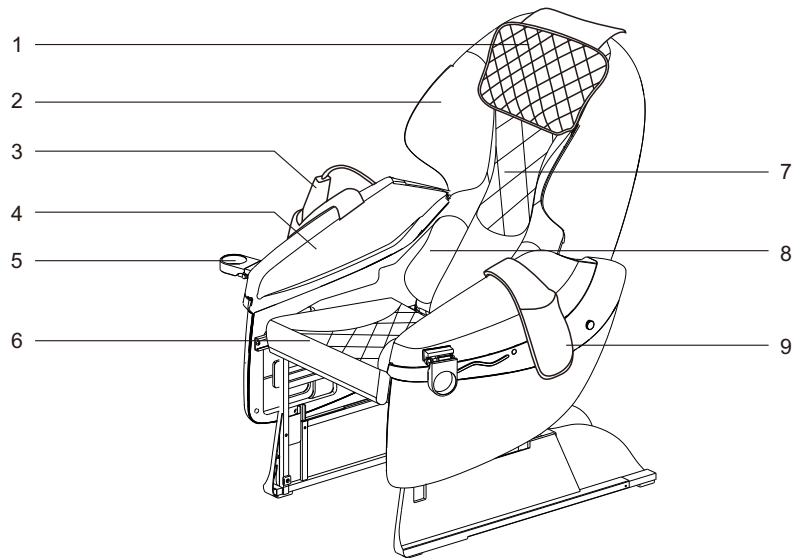

1. Head cushion
2. Shoulder airbag assembly
3. Remote controller
4. Arm airbag assembly
5. Cup holder
6. Seat cushion
7. Back cushion
8. Waist airbag
9. Remote controller pocket

Function

- This product is designed with a set of massage machine hand that can walk up and down.
- Set five kinds of artificial massage techniques: finger pressing, kneading, flapping, knocking flapping and kneading.
- Set automatic massage function: neck massage, body massage, back waist massage
- Set the upper body manual massage function (full, partial, fixed point three massage parts selection, acupuncture, kneading, flapping, flapping, kneading and flapping five kinds of artificial massage techniques; each massage technique has three speeds adjustable, Under the fixed point state, the machine hand can adjust the upper and lower position; when flapping, shiatsu, flapping massage, the width of the massage ball is wide, medium and narrow.
- airbag massage function: hip pressure, upper body pressure, arm pressure (two airbags built into the left and right armrests), a total of eight airbags. Air pressure three mode selection, third gear strength
- The bathtub can be adjusted freely in and out, the backrest frame lifting adjustment and one-button lifting adjustment function.
- With the bathtub shortcut button to adjust the bathtub forward or backward and the backrest angle to tilt freely.

Method of usage

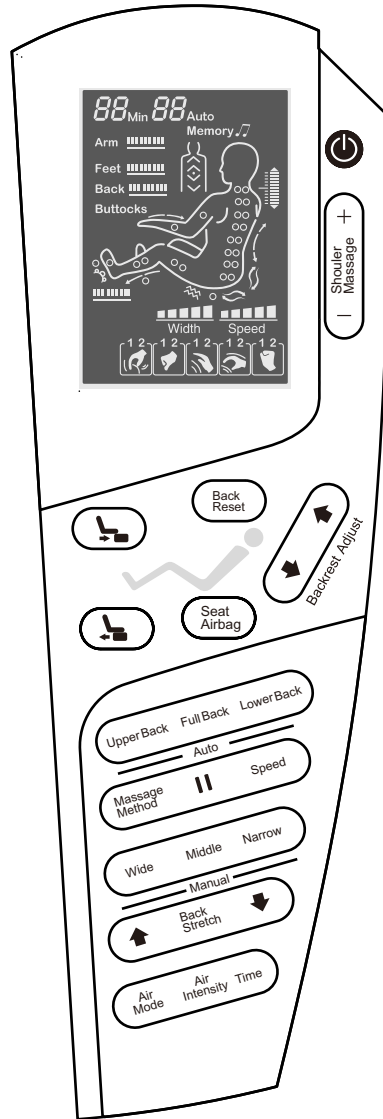

Method of usage

1. Start the massage

- Turn on the power switch, start massage

1). Remote controller operation

Button	Description
	Power switch: Turns all massage functions on or off.

2). Shoulder air pressure intensity adjustment

Button	Description
	The shoulder air pressure is increased and adjust three level
	The shoulder air pressure is decreased and adjust three level

3). One-button reset

Button	Description
	The backrest frame reset with one key

4). Car adjustment

Button	Description
	Press and hold the button to move the bathtub forward, when you hear shortly :BiBiBi.." it means the tub reach the maximum
	Press and hold the button and move the bathtub backwards. when you hear shortly :BiBiBi.." , it means the tub reach the minimum

5). Cushion air Pressure

Button	Description
	Turn on/off the air pressure function

5). Angle Adjustment

Button	Description
	Press and hold the button to raise the backrest, when you hear shortly :BiBiBi.." it means the tub reach the maximum
	Press and hold the button on the backrest to lie down, when you hear shortly :BiBiBi.." it means the tub reach the maximum

Method of usage

7).Automatic Massage

Button	Description
Upper Back	Help blood circulation in the neck.
Full Back	Help body fatigue and relaxes muscles.
Lower Back	Promote body functions.

8).Automatic Massage

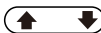
Features	Button	Description
Kneading, Flapping, kneading and Flapping, Shiatsu, knock, Stop	Massage Method	Kneading: Speed.
		knocking: Speed, Width.
		Knocking and Flapping: Speed.
		Shiatsu: Speed, Width.
		Knocking: Speed, Width.
Speed	Speed	Three levels of speed can be adjusted.
Width	Wide	Three levels of width can be adjusted.
Medium and Narrow	Middle	In the manual mode knock, flapping and finger pressing modes, the machine hand can be adjusted in width, middle and narrow.
	Narrow	
Back Stretch	Back Stretch	Fixed position massage.
		Area massage.
		Full massage.
		Press and hold the button in manual mode with the machine hand going up.
Press and hold the button in manual mode with the machine hand going down.		

Method of usage

9).Air pressure massage

Button	Description
Air Mode	Three airbag mode switch buttons.
Air Intensity	Three levels of strength can be adjusted.

10).Time out

Button	Description
	Press to pause and run all massage functions. If pausing time exceeds the set time for 20 minutes during massage, all massage functions will be automatically turned off.

11). Time Setting

Button	Description
Time	Massage time setting.

12). Turn off the power, Finish the massage

- During the massage, turn off the power switch, the backrest frame is lifted, and the machine hand resets all massage functions to stop.

2.Installation instructions

1).Backrest Installation

- First install the backrest shaft into the slot of the frame.
- The backrest support and the backrest electric cylinder mounting holes are aligned; use 8*55mm pins and 1.6*35 quick release pins and 2 isolation sleeves for installation.

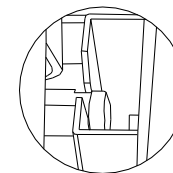
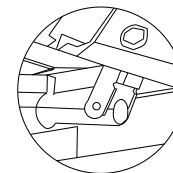

Method of usage

2).Seat Frame Installation

- The male and female buckles of the frame assembly 8 are tightened with a tool hammer.
- Use two m5*16 Phillips flat head screws to lock the frame assembly.

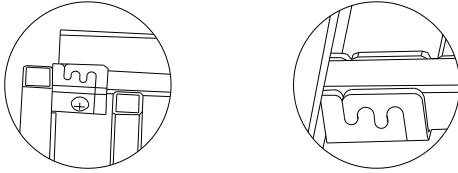

3).Armrest Installation

- The left and right armrests are mounted using four M6*10mm Phillips pan head screws.
- Use 2 8*30 hex socket head cap screws to lock the left and right armrests.

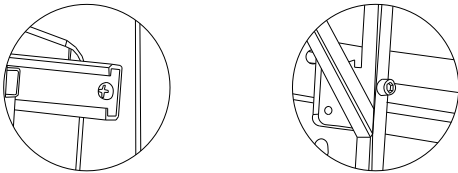

4).Cup Holder Instructions

- This is the state of the tea cup.
- After the cup holder is placed back to the back of the armrest, the cup holder can be put down.

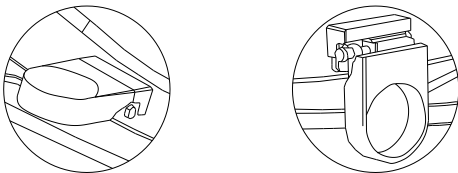

Method of usage

Caution

- (1). The correct method of operation: before operating the controller, please make sure that the backrest electronic cylinder is connected well with the pin that fixes the backrest.
- (2). When the backrest electric cylinder is not connected with the pin that fixes the backrest, please hold the electronic cylinder in case it touches the ground when operate the controller.
- (3). When debugging and installation, before operating the controller, please make sure that the backrest electric cylinder is connected well with the pin that fixes the backrest. Otherwise, after shutting down the switch, the front part of the electronic cylinder will hit the board under the seat frame to cause bad distortion of the seat frame, and even make the rail go out of the railway or damage the steel-ball railway.

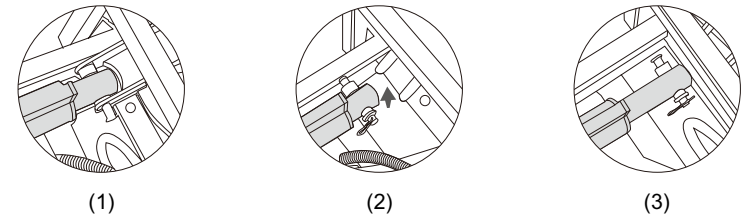

3.Operation sequence

SWITCH ON POWER

- (1).insert the plug into the socket outlet.
- (2).switch on the power button behind the armrest.

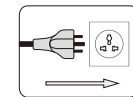

MASSAGE

- (1)Select relative massage according to the operation instructions of the control.

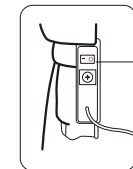

SWITCH OFF POWER

- (1).stop overall massage.
- (2).switch off the power button behind the armrest.
- (3).pull the plug out of the socket outlet.

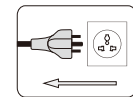

Method of usage

4. Attaching or detaching the pillow pad and back cushion

The pillow pad and back cushion (recommended) reduces the kneading intensity of your neck and shoulder, but you can decide to put it on or not according to your personal need. (1) Sticker connects the pillow pad and back cushion.

WARNING : IN CASE OF DANGER, DO NOT REMOVE THE CUSHION

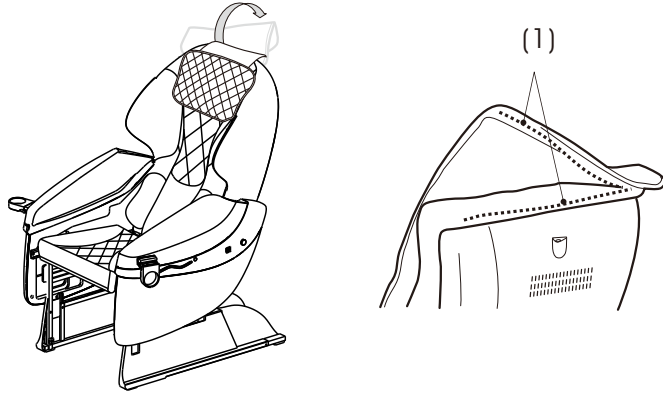

5. To Adjust The Back Simultaneously

Backrest adjustment

press and hold the  button on the controller, the backrest will recline backward slowly. Release the button, then the backrest will be stopped upright

press and hold the  button on the controller, the backrest will move slowly.

Loose the button, then the backrest will be stopped .

WARNING: DO NOT EXERT ANY PRESSURE OTHER THAN YOUR OWN BODY ON THE BACK WHILE IT IS RISING.

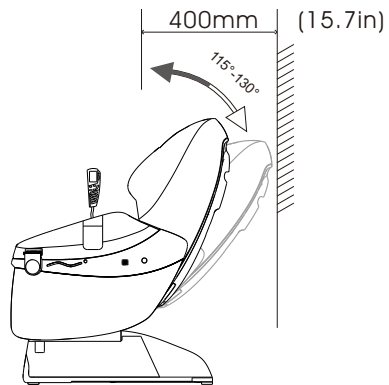

12

Method of usage

6. To Adjust Seat Frame Separately

The flex function of seat frame could fix the different height of the people to adjust the massage place of the calf airbags, the maximum distance moving forward and backward is 400mm.

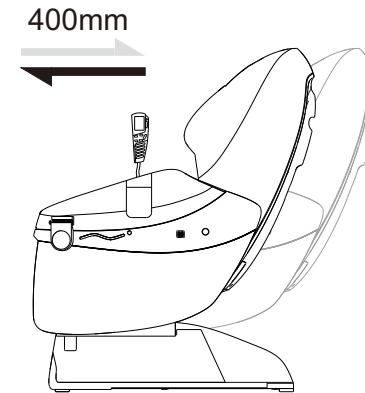

Product specification

Model: G501

Name: SPA Massage Chair

Power supply: 110-120V~ 50Hz/60Hz
220-240V~ 60Hz

Rated power: 90W

Safety structure: Class Ⅲ

13